

OPERATING INSTRUCTIONS MANUAL

(Please retain for future reference)

For

FVO-200RC INDIRECT FIRED SPACE HEATERS

CERTIFIED FOR USE IN CANADA AND U.S.A.

As per CSA B140.8 Portable Oil Fired Heaters / CSA B140.02003 Oil Burning Equipment

UL733 Oil fired heaters

Construction Heaters Unattended Type.



Issue date: July 1, 2017



**FLAGRO INDUSTRIES LIMITED
ST. CATHARINES, ONTARIO
CANADA**

GENERAL HAZARD WARNING:

FAILURE TO COMPLY WITH THE PRECAUTIONS AND INSTRUCTIONS PROVIDED WITH THIS HEATER, CAN RESULT IN DEATH, SERIOUS BODILY INJURY AND PROPERTY LOSS OR DAMAGE FROM HAZARDS OF FIRE, EXPLOSION, BURN, ASPHYXIATION, CARBON MONOXIDE POISONING, AND/OR ELECTRICAL SHOCK.

ONLY PERSONS WHO CAN UNDERSTAND AND FOLLOW THE INSTRUCTIONS SHOULD USE OR SERVICE THIS HEATER.

IF YOU NEED ASSISTANCE OR HEATER INFORMATION SUCH AS AN INSTRUCTIONS MANUAL, LABELS, ETC. CONTACT THE MANUFACTURER.

WARNING:

FIRE, BURN, INHALATION, AND EXPLOSION HAZARD. KEEP SOLID COMBUSTIBLES, SUCH AS BUILDING MATERIALS, PAPER OR CARDBOARD, A SAFE DISTANCE AWAY FROM THE HEATER AS RECOMMENDED BY THE INSTRUCTIONS. NEVER USE THE HEATER IN SPACES WHICH DO OR MAY CONTAIN VOLATILE OR AIRBORNE COMBUSTIBLES, OR PRODUCTS SUCH AS GASOLINE, SOLVENTS, PAINT THINNER, DUST PARTICLES OR UNKNOWN CHEMICALS.

WARNING:

NOT FOR HOME OR RECREATIONAL VEHICLE USE.

WARNING:

INTENDED USE IS PRIMARILY THE TEMPORARY HEATING OF BUILDINGS UNDER CONSTRUCTION, ALTERATION, REPAIR OR EMERGENCIES ONLY.

This heater is designed and approved for use as a construction heater under CSA B140.8 Portable Oil Fired Heaters / CSA B140.02003 Oil Burning Equipment & UL733 Oil Fired heaters.

We cannot anticipate every use which may be made of our heaters. CHECK WITH YOU LOCAL FIRE SAFETY AUTHORITY IF YOU HAVE QUESTIONS ABOUT APPLICATIONS.

Other standards govern the use of fuel gases and heat producing products in specific applications. Your local authority can advise you about these.

SPECIFICATIONS

Model	FVO-200RC
Input	BTUH Range
	185,000 Btu
Fuel	No.1, No. 2, diesel or kerosene
Fuel Pressure	180 psi
Nozzle	1.10 x 70A
Electrical	115V 15 AMP
Ignition	Direct Spark Ignition
.....	Thermostat Control
Air Circulation	2600 cfm
Fuel Consumption	1.30 Gal/hr
Approved	cETLus listed

INSTALLATION:

The installation of this heater for use with No.1, No.2, Diesel or Kerosene and shall conform with local codes or, in the absence of codes, with the National Fuel Gas Code ANSI Z223.1/NFPA 54. For recommended installation practices refer to CSA Standard B139.

CLEARANCE TO COMBUSTIBLES:

<u>TOP</u>	<u>FRONT</u>	<u>SIDES</u>	<u>REAR</u>	<u>FLUE PIPE</u>
3 ft	10 ft	1 ft	2 ft	3 ft

FUEL: This heater will operate with No.1, No.2, Diesel or Kerosene.
Note: No.1 Fuel Oil or Kerosene must be used for temperatures less than -10° C (8° F).

ELECTRICAL:

WARNING **Electrical Grounding Instructions**

This appliance is equipped with a three-prong (grounding) plug for your protection against shock hazard and should be plugged directly into a properly grounded three-prong receptacle.

115v supply must be available. Please note that the heater requires 15 amps for proper operation. Ensure appropriate gauge extension cord is used.

- 12/3 AWG at 50 Feet
- 10/3 AWG at 100 Feet

POWER SUPPLY INDICATOR LIGHT:

The power supply indicator light will help detect any faulty power supplied to the heater such as; grounding issues, reverse polarity or missing/poor connections.

Warning Light Indications

Green Light Meets Power Requirements

Solid Red Light..... Reverse Polarity

Solid Red & Green Light... Ground Issue



ATTENTION: IF SOLID RED & GREEN IS INDICATED, MAKE CORRECTIONS TO POWER SUPPLY BEFORE TURNING HEATER ON. FAILURE TO DO SO WILL VOID ANY WARRANTY.

FLUE PIPE:

Flue pipe connection must terminate with a vertical run at least 2ft long. Horizontal runs should have a rise ratio of 1 in 10 away from the heater. The chimney should have a 0.2" W.C. draft to ensure safe operation of the unit.

The vent outlet on the heater is 6" diameter. Certified venting must be used at all times. Vent cap should be installed in situations where downdrafts occur. All venting must correspond with the CSA B149 standard or in its absence, local codes.

FV SERIES CONSTRUCTION HEATER – VENTING REQUIREMENTS

1. VERTICAL FLUE TERMINATIONS

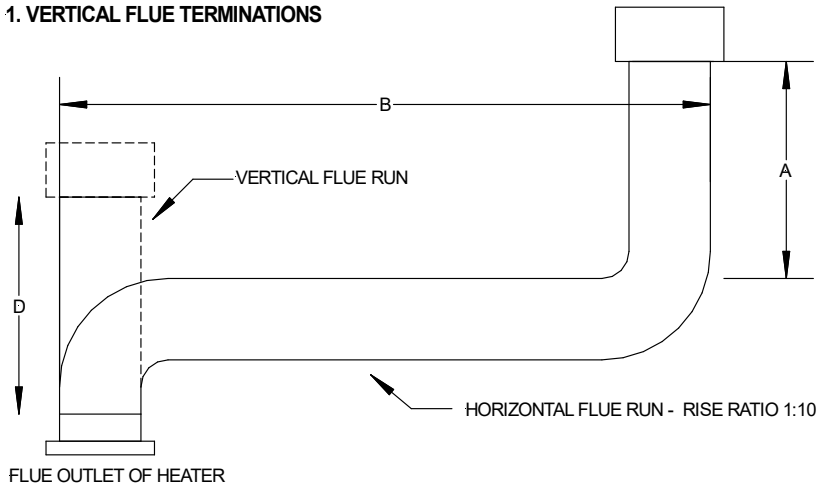

2. HORIZONTAL FLUE TERMINATIONS

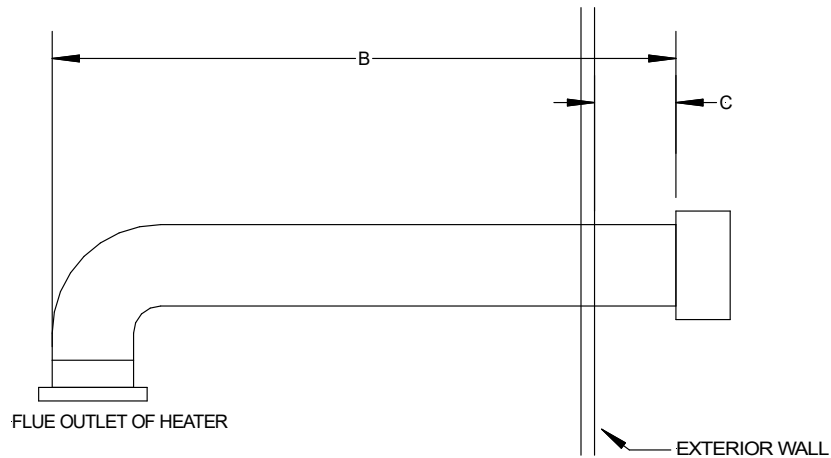

- A - VENT TERMINATION MUST BE A MINIMUM OF 2FT HIGHER THAN ANY POINT WITHIN 10FT.
- B - MAXIMUM HORIZONTAL RUN IS 30FT.
NOTE: 90deg ELBOW = 10ft HORIZONTAL VENT ALLOWANCE
45deg ELBOW = 5ft HORIZONTAL VENT ALLOWANCE
- C - VENT TERMINATION IN HORIZONTAL POSITION MUST BE MINIMUM 4ft FROM ANY COMBUSTABLE SURFACE
- D - EXTERIOR VERTICAL VENT TERMINATION MUST BE A MINIMUM OF 2ft.

NOTE: ALL VENT TERMINATIONS MUST HAVE A RAIN CAP INSTALLED AS PER LOCAL CODE REQUIREMENTS.

OUTLET DUCTING:(maximum of 150ft to be used)

Heater duct with a minimum temperature handling of 350 deg F including wire reinforcement to prevent collapsing. Heater is designed for use with 12" (FV-HD12) or 16" (FV-HDG16) diameter ducting equipped with pin lock or cuff & buckle provided on collar for ducting. Ducting should be inspected periodically for tearing and/or wear marks. Ducting should be stored in a dry area when not in use.

INLET DUCTING:

Inlet ducting can be used on the return air inlet of heater. The heater is designed for 12" inlet diameter ducting with pin lock or cuff and buckle system.

MAINTENANCE:

1. **Every construction heater should be inspected before each use, and at least annually by a qualified service person. Incorrect maintenance may result in improper operation of the heater and serious injury could occur.**
2. The hose assemblies shall be visually inspected prior to each use of the heater. If it is evident there is excessive abrasion or wear, or the hose is cut, it must be replaced prior to the heater being put into operation. The replacement hose assembly shall be that specified by the manufacturer.
3. The flow of combustion and ventilation air must not be obstructed. Be sure to check the fan assembly and ensure that the motor and blade are operating properly.
4. Compressed air should be used to keep components free of dust and dirt build up. Note: Do not use the compressed air inside any piping or regulator components.
5. Change fuel filter insert (Part# FVO-418) once per month. Change fuel filter cartridge (Part# FVO-419) once every 6 months.
6. Change oil nozzle (Part# FV-235B) once per year.
7. Fan Limit Switch (Part# FV-407A) should be replaced if the fan motor does not shut off after the heat exchanger has cooled down.
8. The High Limit Switch (Part# FV-406) should be checked each season. This limit switch will ensure the burner shuts down if the temperature exceeds 250° F at the outlet.
9. Fuel tank should be drained on a regular basis by removing drain plug.
10. **CAUTION** – Do not have any source of ignition near the heater when draining tank.

NOTE: No.1 fuel oil or kerosene is recommended for temperatures below -10° C / 8° F.

11. Heat Exchanger should be cleaned if smokey conditions continue even after the air adjustments on the burner are made.

START UP INSTRUCTIONS:

1. Position heater properly on a level surface.
2. Be sure the toggle switch in is the "OFF" position.
3. Ensure burner "air gate" is properly set at 3.
4. Ensure electrical cord is grounded and plugged into a 120V 15AMP outlet. Verify cord size (12/3AWG at 50ft & 10/3AWG at 100ft)
5. The power indicator light on the control box will engage. If the green light illuminates, you have proper power supply. If not, refer to sticker on heater to verify warning problem. Correct power supply problem before operating heater.
6. Move toggle switch to "MANUAL" position for manual control.
7. Move toggle switch to "THERMOSTAT" position for thermostat control. Thermostat must be plugged into heater first.

Please Note:

1. If using Thermostat on unit, unit must be started in Thermostat position.
2. When changing between manual and thermostat operation, the heater must be left in the "OFF" position for 30 seconds to prevent the burner from locking out.
3. When using a generator for electrical supply, make sure the generator is properly grounded and generator is at a 60Hz frequency.
4. In the event that a Generator is being used and the generator runs out of fuel, make sure the heater switch is in the "OFF" position before restarting generator, failure to do so may damage heater.

TO SHUT DOWN:

1. Move toggle switch to "OFF" position. Do not disconnect power supply until the heat exchanger cools down

NOTE: Fan will continue to operate after the burner shuts down. Once the unit cools down, the fan will stop.

IF HEATER FAILS TO START:

1. Press manual reset button at rear of burner.
2. Check fuel level. There must be 2-4 gallons of fuel in the tank for the heater to start properly.
3. Make sure there are no air locks in fuel lines or filter.
4. Ensure proper power supply and extension cord is being used.
5. Check for dirty fuel filter or blocked fuel supply line.
6. Check burner nozzle assembly.

NOTE: IF THE BURNER HAS BEEN RESET SEVERAL TIMES THERE MAY BE AN ACCUMULATION OF OIL IN THE CHAMBER! DO NOT CONTINUE TO TRY AND START THE HEATER!

DRAIN OIL FROM HEAT EXCHANGER USING DRAIN HOLE AT FRONT OF HEAT EXCHANGER FOR 15-20 MINUTES BEFORE ATTEMPTING TO RELIGHT. LET REMAINING EXCESS OIL BURN OFF BEFORE CHECKING COMBUSTION OF UNIT.

SAFE OPERATION PRECAUTIONS:

1. Do not fill fuel tank while heater is operation.
2. Do not attempt to start heater if excess oil remains in the heat exchanger.
3. Use switch to shut down the heater. Do not try to shut down the heater by unplugging the electrical cord.
4. Do not plug anything other than the thermostat into the "Thermostat" plug.
5. Do not use any fuel other than those listed on rating plate.
6. Follow electrical requirements shown on rating plate and/or Electrical requirements section of this manual.
7. Before removing any guards or performing any maintenance, be sure that the main power supply is disconnected.

COMBUSTION AIR ADJUSTMENTS:

NOTE: Proper combustion air adjustment must be achieved using a certified combustion analyzer and smoke tester to ensure complete combustion.

The air adjustment should be made to achieve 10% CO₂ and No. 1 or "trace" smoke. (Bacharach Scale)

SETTING THE AIR ADJUSTMENT PLATE

A) Regulation of the combustion air flow is made by adjustment of the manual AIR ADJUSTMENT PLATE (1) after loosening the FIXING SCREWS (2 & 3). The initial setting of the air adjustment plate should be made according to Column 5 in the Burner Set-up Chart.

B) The proper number on the manual AIR ADJUSTMENT PLATE (1) should line up with the SETTING INDICATOR

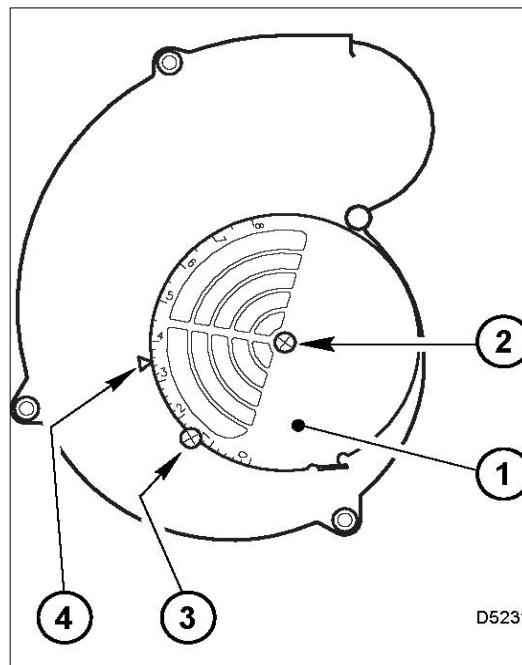

(4) on the fan housing cover. Once set, the air adjustment plate should be secured in place by tightening SCREWS 2 and 3.

C) The final position of the air adjustment plate will vary on each installation. Use instruments to establish the proper settings for maximum CO₂ and a smoke reading of zero.

NOTE: Variations in flue gas, smoke, CO₂ and temperature readings may be experienced when the burner cover is put in place. Therefore, the burner cover **must** be in place when making the final combustion instrument readings, to ensure proper test results.

BURNER SET-UP CHART

1	2	3		4	5
ACTUAL FIRING RATE ± 5%	NOZZLE SIZE	PUMP PRESSURE		TURBULATOR SETTING	AIR DAMPER SETTING
GPH	GPH	PSI	BAR		
1.30	1.10 x 70°A	180	12.41	3	3.5

* Note – Air damper setting is typically set at 3.5 for operation in colder temperatures. A combustion analyzer should always be used when setting the burner.

TEMPERATURE FEELER GAUGE ADJUSTMENT (ATTACHED TO FAN SWITCH)

The temperature feeler gauge is required to be always touching the heater exchanger.

The temperature feeler gauge controls the air flow over the fan switch, which eliminates any unnecessary fan cycling. The temperature feeler gauge can be adjusted for different outside temperatures, by rotating the location of the temperature feeler gauge holes. This will provide maximum performance of the unit in different applications.

If supply air is warm (-5° C, indoor application):

Turn the temperature feeler gauge so that the holes are parallel with the heat exchanger. This will help the fan switch to remain cool and not overheat. See following:

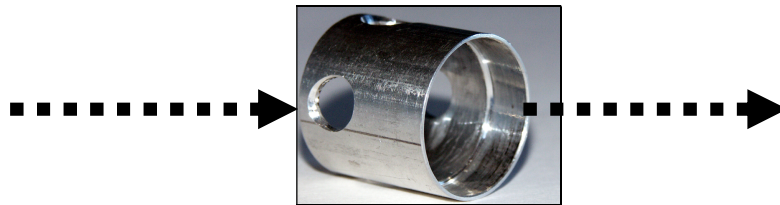

If supply air is cold (under -5°C):

Turn the temperature feeler gauge so that the holes are closed off as the air goes over the heat exchanger. This will reduce fan cycling and the unit from shutting down. See following:

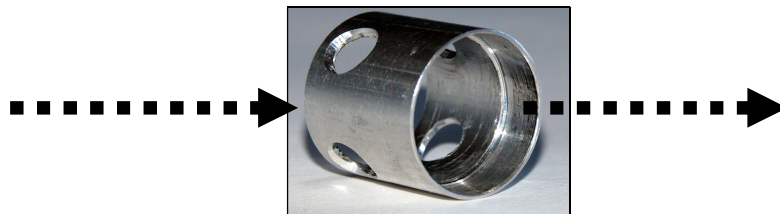

In extreme cold conditions, cover the holes on the temperature feeler gauge using foil tape or replace feeler gauge with part# FV-433B Solid feeler gauge. Ensure that the temperature feeler gauge is readjusted for warmer weather conditions. Failure to do so may result in burning out fan switches- not covered under warranty.

ELECTRICAL CONNECTIONS

It is advisable to leave the control box off the sub-base while completing the electrical connection to the burner.

- 1) Wire access hole (Use BX electrical connector)
- 2) Earth ground conductor terminal (Green wire)
- 3) Hot conductor terminal (Black wire)
- 4) Neutral conductor terminal (White wire)
- 5) Strain relief clamp

WARNING: The hot (black) wire must be connected to the L terminal and the neutral (white) wire must be connected to the N terminal or the primary safety control will be damaged. Do not connect wither wire to the terminal marked 

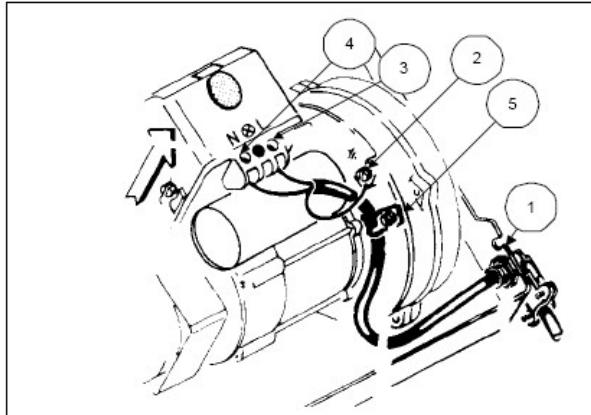

The burner may be controlled using either a DIRECT LINE VOLTAGE control circuit (120V AC 60 cycle) OR a LOW VOLTAGE control switching relay.

Using the appropriate diagram below, make electrical connections to burner. All wiring must be done in accordance with existing electrical codes, both national and local. When all electrical connections have been made, the control box may be put back in place on the sub-base.

WARNING: DO NOT activate burner until proper oil line connections have been made, or failure of the pump shaft seal may occur.

APPLICATION FIELD WIRING

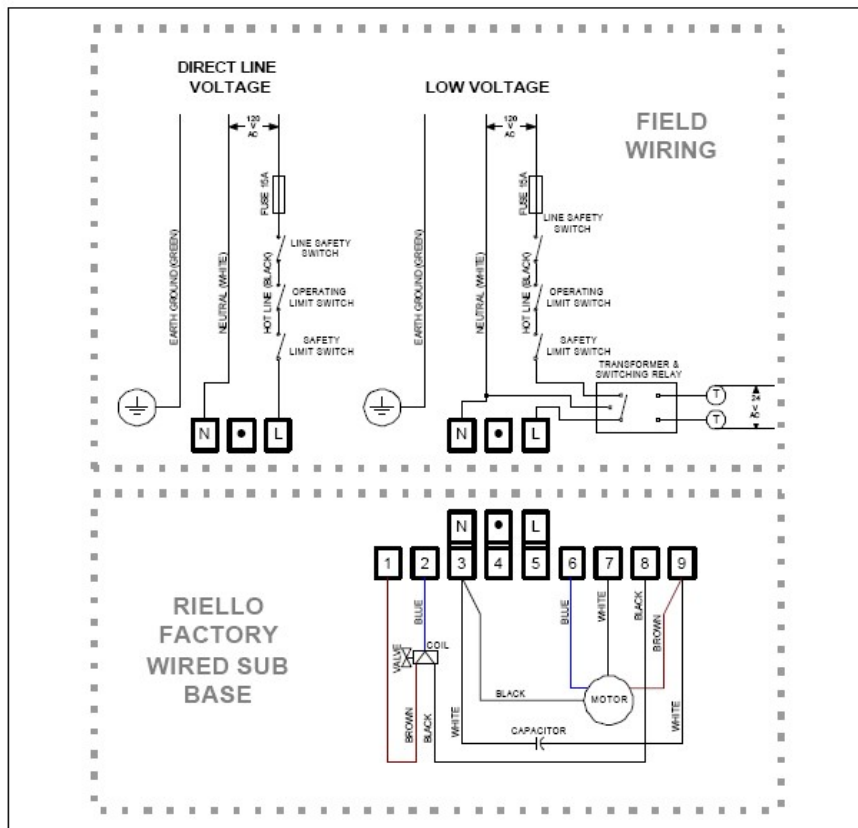

REMOTE SENSING OF SAFETY LOCKOUT: The SAFETY SWITCH in the 530SE CONTROL BOX is equipped with a contact allowing remote sensing of burner lockout. The electrical connection is made at terminal 4 (•) on the SUB-BASE. Should lockout occur the 530SE CONTROL BOX will supply a power source of 120Vac to the connection terminal. The maximum allowable current draw on this terminal (4) is 1 Amp.

WARNING: If a neutral or ground lead is attached to this terminal, the CONTROL BOX on the burner will be damaged should lockout occur.

INSERTION / REMOVAL OF DRAWER ASSEMBLY

- A)** To remove drawer assembly, loosen SCREW (3), then unplug CONTROL BOX (1) by carefully pulling it back and then up.
- B)** Remove the AIR TUBE COVER PLATE (5) by loosening the two retaining SCREWS (4).
- C)** Loosen SCREW (2), and then slide the complete drawer assembly out of the combustion head as shown.
- D)** To insert drawer assembly, reverse the procedure in items A to C above, and then attach fuel line to the pump.

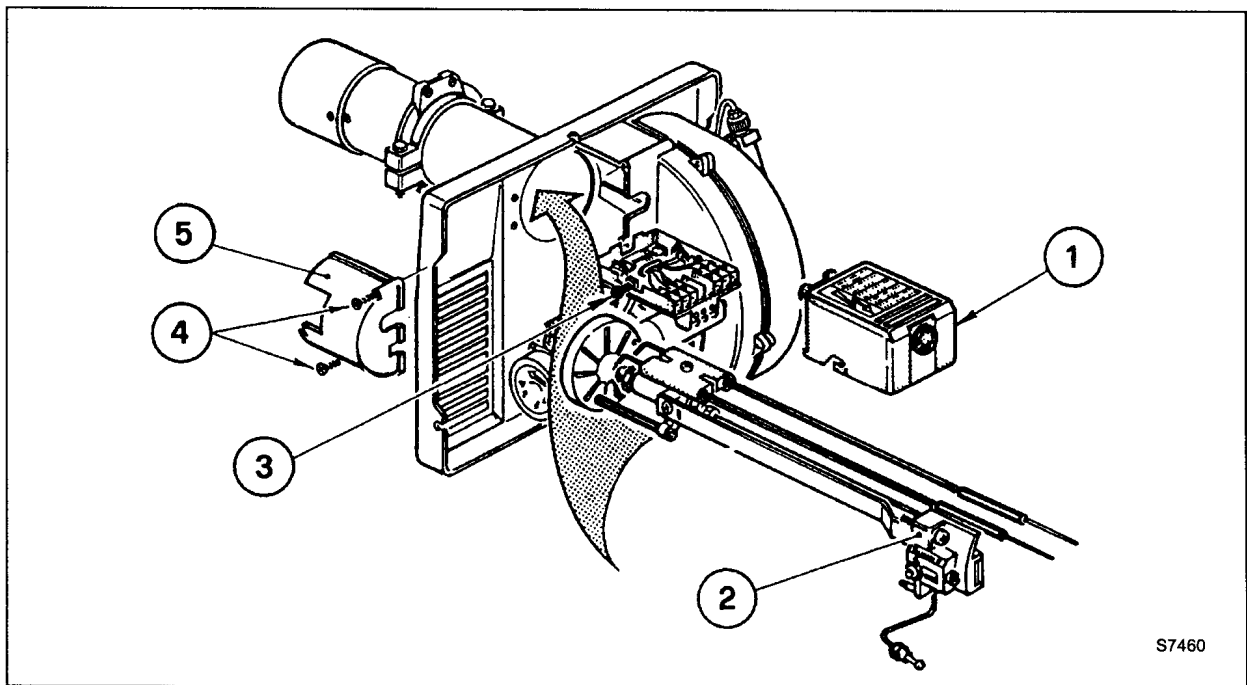

NOZZLE PLACEMENT

- A) Remove the NOZZLE ADAPTER (2) from the DRAWER ASSEMBLY by loosening the SCREW (1).

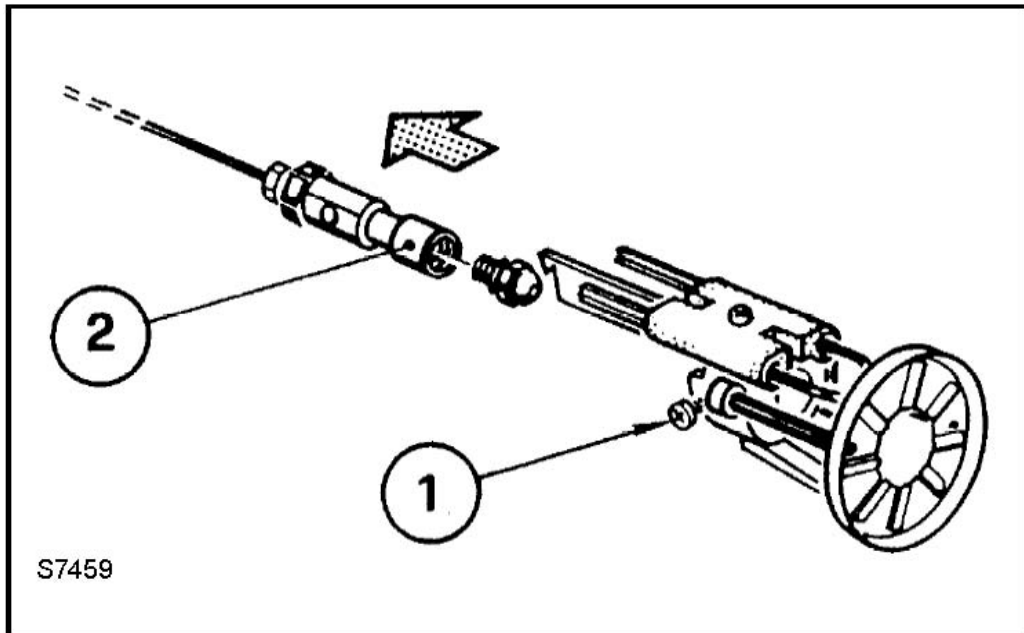

- B) Insert the proper NOZZLE into the NOZZLE ADAPTER and tighten securely (Do not over tighten).
- C) Replace adapter, with nozzle installed, into drawer assembly and secure with screw (1).

ELECTRODE SETTING

IMPORTANT: THIS DIMENSIONS MUST BE OBSERVED AND VERIFIED.



TURBULATOR SETTING

- A)** Loosen NUT (1), then turn SCREW (2) until the INDEX MARKER (3) is aligned with the correct index number as per the Burner Set-up chart, on page 12.
- B)** Retighten the RETAINING NUT (1)

NOTE: Zero and five are scale indicators only. From left to right, the first line is 5 and the last line 0.

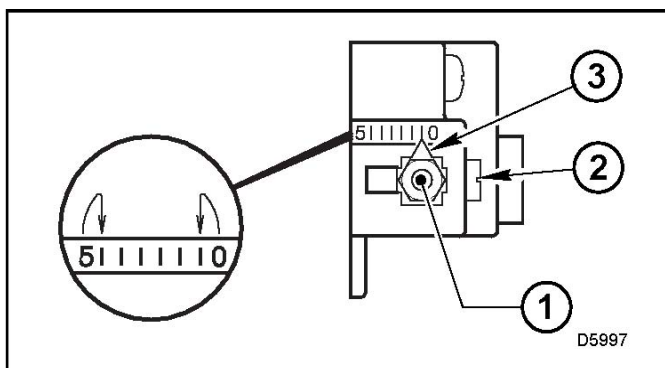

OIL LINE CONNECTIONS

Note: Pump pressure must be set at time of burner start-up. A pressure gauge is attached to the PRESSURE PORT (8) for pressure readings. Two PIPE CONNECTORS (5) are supplied with the burner for connection to either a single or a two-pipe system. Also supplied are two ADAPTORS (3), two female 1/4" NPT, to adapt oil lines to burner pipe connectors. All pump port threads are British Parallel Thread design. Direct connection of NPT threads to the pump will damage the pump body. Riello manometers and vacuum gauges do not require any adaptors, and can be safely connected to the pump ports. An NPT (metric) adapter must be used when connecting other gauge models.

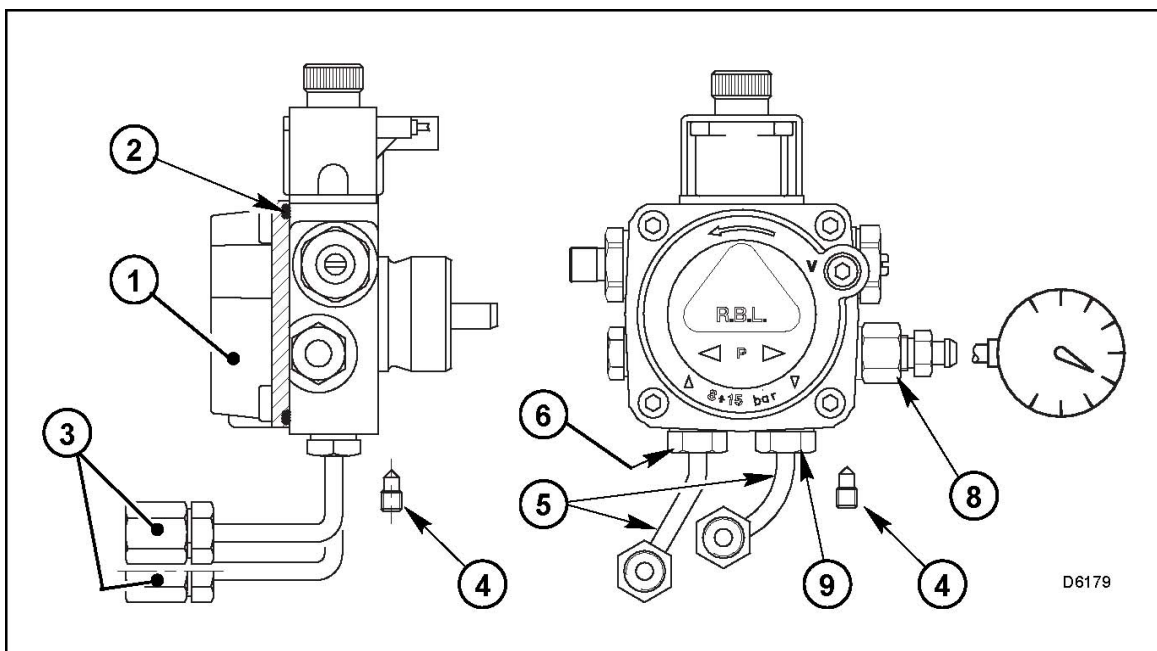

F-5 OIL FIRED BURNER - PARTS DIAGRAM

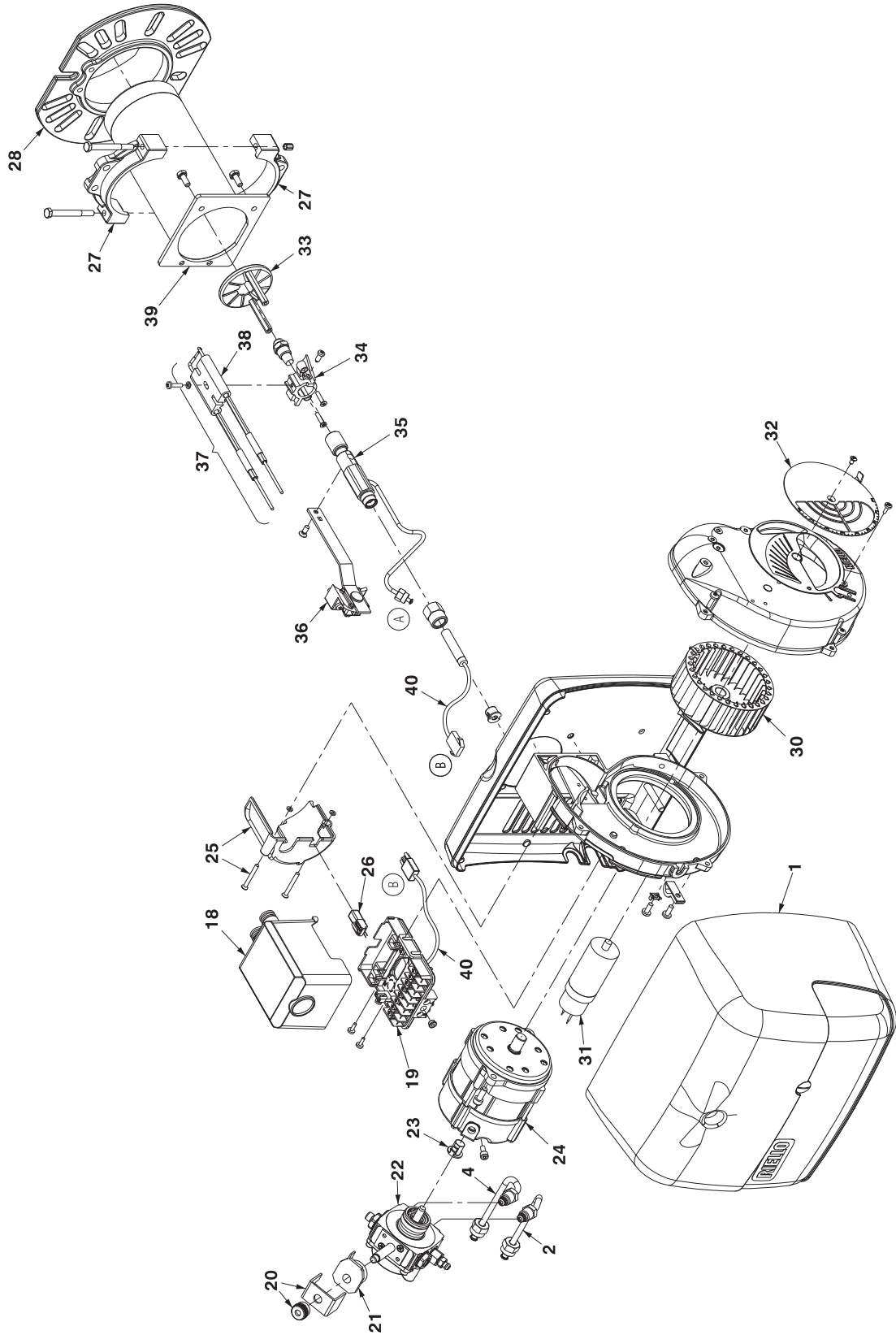

RIELLO BURNER F5 - PARTS LIST DIAGRAM		
N#	PART NUMBER	DESCRIPTION
1	FV-20136483-OIL	PLASTIC BURNER COVER C/W LABELS
2	FVO-3006993	RETURN LINE
4	FVO-3006992	SUPPLY LINE
18	FVO-C700-1029	IGNITION MODULE
19	FVO-3002278	SUB-BASE FOR IGNITION MODULE
20	FVO-3006553	COIL U-BRACKET C/W KNURLED NUT
21	FVO-3002279	PUMP COIL
22	FVO-20136488	BURNER PUMP
23	FVO-3000443	PUMP DRIVE KEY
24	FVO-C7001034	BURNER MOTOR
25	FVO-3007316	AIR TUBE COVER PLATE
26	FVO-20132573	PHOTO CELL
27	FVO-3005854	SEMI FLANGE
28	FV-3005855	MOUNTING FLANGE
30	FV-3005708	BURNER FAN
31	FVO-3005844	BURNER CAPACITOR
32	FVO-3007204	AIR DAMPER
33	FVO-3006977	TURBULATOR DISC
34	FVO-3006966	ELECTRODE SUPPORT
35	FVO-20136490	NOZZLE HOLDER
36	FVO-3006323	REGULATOR ASSEMBLY
37	FVO-3006329	ELECTRODE ASSEMBLY
38	FVO-3005869	ELECTRODE PORCELAIN
39	FVO-3007594	BLAST TUBE
40	FVO-20136491	PREHEATER



26 Benfield Drive , St.Catharines Ontario Canada
 905-685-4243
 12949 Eagle Creek Parkway, Savage MN USA
 866-266-2484

FVO-200RC – PARTS LIST



1/2 HP MOTOR

FV-201



14" IMPELLER

FV-202RC



VENTURI FOR 14" BC IMPELLER

FV-202RCA



12" WHEEL FLAT FREE

FV-203A



6" LOCKABLE CASTER WHEEL

FV-207



SS HEAT EXCHANGER

FV-205



HIGH LIMIT OUTLET (180F)

FV-242

HIGH LIMIT BURNER (150F)

FV-437



FAN LIMIT SWITCH

FV-407A



FAN LIMIT GASKET

FV-407G



FEELER GAUGE

HOLES – FV-433

SOLID – FV-433B



TOGGLE SWITCH

FV-409



RED LIGHT

FV-411



**POWER INDICATOR
LIGHT**

FV-450SI



**THERMOSTAT PLUG
(ON CONTROL BOX)**

FV-414B



POWER CORD

FV-204

FVO-200RC – PARTS LIST



**THERMOSTAT PLUG
(PLUG ON THB)**

FV-415A



**CONTROL BOX
(EMPTY)**

FV-2P08RC



CONTROL LID

FV-2P09RC



**HIGH LIMIT BOX (1 HOLE)
FV-P11
HIGH LIMIT BOX (2 HOLES)
FV-P10**



LIMIT BOX LID

FV-P12



WHEEL AXLE

FV-240



RC HOOD

FV-208RC



Canopy Inlet Ring

FV-208IR.com



Canopy Faceplate

FV-208FP.com



MOTOR MOUNT BRACKET

FV-2P05RC



REAR BURNER MOUNT PANEL

FV-2P04RC



**FRONT FACEPLATE
FV-234CB12 – 12”
FV-234CB16 – 16”**



HEATER FRAME

FVO-2FRC



TOP BODY PANEL

FV-2P01RC



BOTTOM BODY PANEL

FV-2P02

FVO-200RC – PARTS LIST

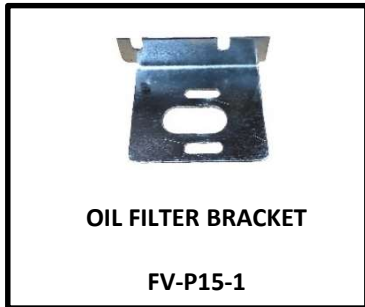
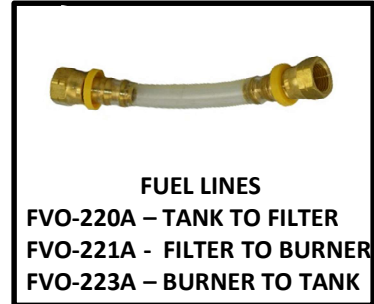
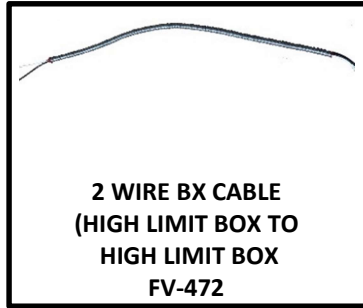

FVO-200RC – PARTS LIST



RETURN LINE ELBOW
FVO-423B



3/8" SHUT OFF VALVE
2103-C-CGA



BRASS ELBOW
3/8" FP X 3/8" FLARE
50-6C



PUMP INLET/OUTLET
ADAPTER
FV-461



BRASS ADAPTER
3/8 FLARE X 1/4 M.P
48-6B



BRASS ADAPTER
3/8" FLARE X 3/8" MP
48-6C



BRASS ELOW
3/8" MP X 3/8" FLARE
49-6C



BRASS ADAPTER
3/8" MP X 3/8" MP
122-C

PARTS LIST FOR FVO-200RC

Part Number	Part Description
FV-201	1/2 HP Fan Motor
FV-202RC	14" BC Impeller
FV-202RCA	14" BC Impeller Venturi
FV-203A	12" Wheel FLAT FREE
FV-204	12" Power Cord c/w Plug End
FV-205	SS Heat Exchanger
40-113-D3.5GALV	1/2" X 3.5" Galvanized Nipple
40-108-8GALV	1/2" Galvanized Cap
FVO-2FRC	Heater Frame
FV-2P01RC	Top Body Panel
FV-2P02	Bottom Body Panel
FV-2P04RC	Rear Burner Mount Panel
FV-2P05RC	Motor Mount Bracket
FV-208RC	Recirculating Hood Canopy
FV-208FP.COM	Canopy Inner Faceplate
FV-208IR.COM	Canopy inlet Ring
FV-2P08RC	Control Box
FV-2P09RC	Control Box Lid
FV-P10	Limit Box - 2 hole
FV-P11	Limit Box - 1 hole
FV-P12	Limit Box Lid
FV-242	High Limit Switch (Outlet) 180F
FV-407A	Fan Limit Switch (Adjustable)
FV-407G	Fan Limit Silicone Gasket
FV-207	Lockable Caster Wheel
FV-409	Toggle Switch (on control box)
FV-411	Red Light (on control box)
FV-414B	Thermostat Plug (on box control)
FV-415A	Male Connector for FV-THB
FVO-215	Riello F5 Burner (Oil)
FVO-216A	23 US Gallon Oil Tank
FVO-216G	Fuel Gauge
FVO-416GG	Fuel Gauge Grommet

FVO-416TG	Supply/Return line Grommet
FVO-417B	Oil Tank Cap
121-B	Oil Tank Drain Plug
FVO-418	Fuel Filter (Complete)
FVO-419	Fuel Filter (insert Only)
FV-P15-1	Filter Bracket
FVO-220A	Clear Fuel Line 6" (Tank to Filter)
FVO-221A	Clear Fuel Line 7.5" (Filter to Burner)
FVO-222A	Clear Fuel Return Line (Burner to Tank)
48-6B	Brass Fitting (Tank to inlet Fuel Line)
48-6C	Brass Fitting (Inlet Side of Filter)
2103-C-CGA	3/8" Shut Off Valve
122-C	3/8" Brass Hex Nipple
50-6C	3/8" FP X 3/8" MP Brass Elbow
49-6C	3/8" MP X 3/8" F.FL Brass Elbow
FV-461	Inlet/Outlet Burner Pump Fitting
FVO-223A	Tank Pick Up Tube c/w Adapter
FVO-423B	Tank Return Line Elbow
FV-231	Burner Gasket
FV-433	Feeler Gauge
FV-234CB12	Front Face Plate (1 x 12")
FV-234CB16	Front Face Plate (1 x 16")
FV-235B	Oil Burner Nozzle (1.10 x 70A)
FV-437	High Limit (Rear) 150F
FV-240	Wheel Axle
FV-446	Sight Glass c/w Fiber Gasket
FV-447	Sight Glass Washer
FV-450SI	Power Indicator Light

	ACCESSORIES
FV-HD12	12" x 12FT HiTex Vinyl Ducting
FV-HD12X25	12" x 25FT HiTex Vinyl Ducting
FV-HDG16	16" x 25FT HiTex Vinyl Ducting
FV-THB	Thermostat c/w 25 FT Cord
FV-THB (15M)	Thermostat c/w 50 FT Cord
FV-VK	6" x 3FT C-Vent c/w Rain Cap

FV-200RC SERIES - WIRING SCHEMATIC 2018

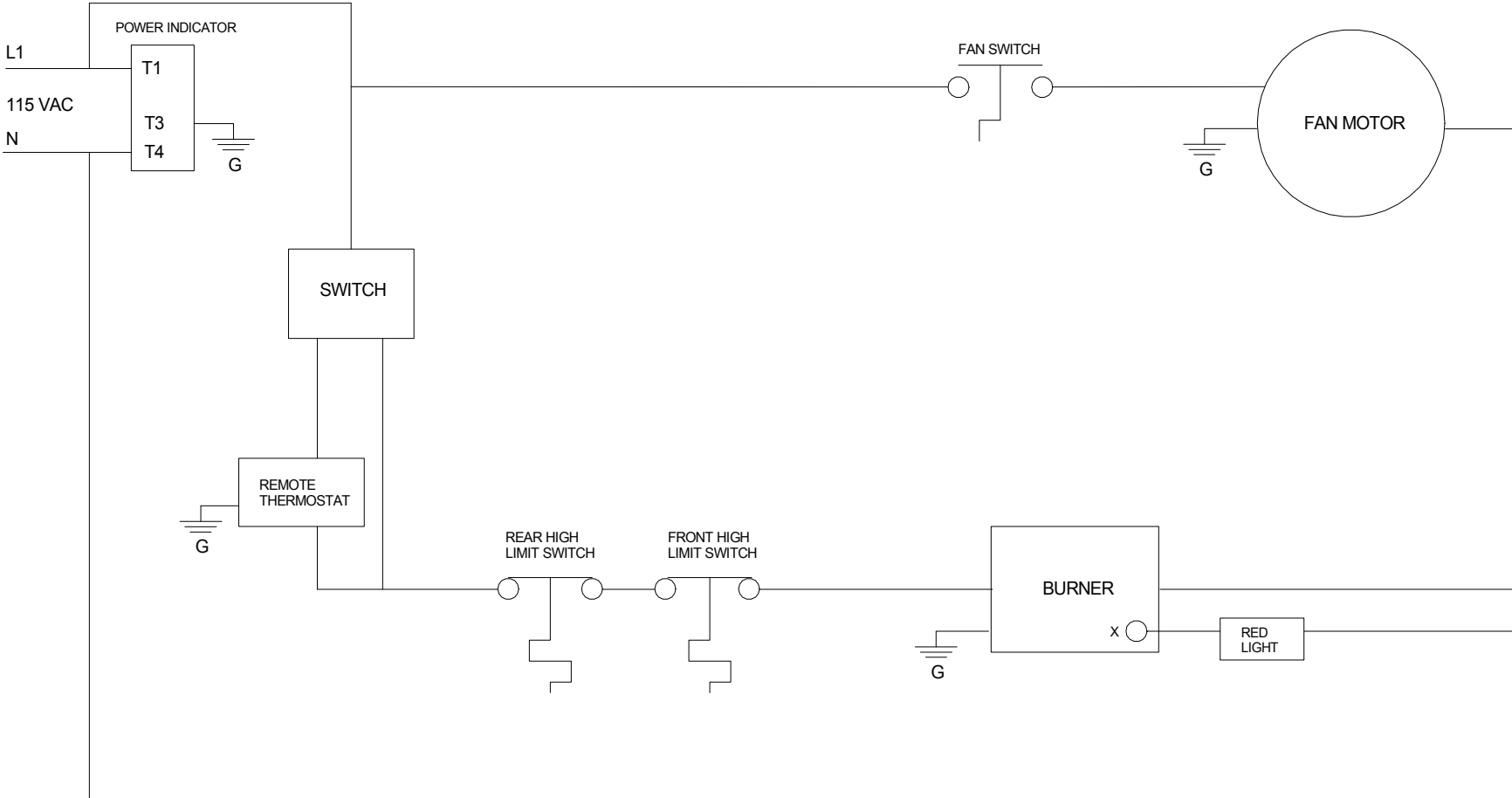

FLAGRO INDUSTRIES LIMITED	
TITLE: FV-200RC - WIRING SCHEMATIC	DWG. NO.: FV-200RC.WS.2018